



Get Ready!

*Alaska's emergency preparedness  
toolkit for people with disabilities*

State of Alaska  
Sean Parnell, Governor

Department of Health and Social Services  
William J. Streur, Commissioner



## Developed by

The State of Alaska Health and Disability Program, with help from:

The University of Alaska Anchorage Center for Human Development's LEND (Leadership Education in Neurodevelopmental and Related Disabilities) Program

The Division of Public Health's Section of Women's, Children's, and Family Health and the Section of Emergency Programs

We gratefully acknowledge the Center on Community Accessibility, a program of the Oregon Institute on Disability & Development, for allowing us permission to adapt their "Ready Now! Emergency Preparedness Toolkit for People with Disabilities."

We especially appreciate colleagues in the Oregon Office on Disability & Health: Danielle Bailey, MPH, Denise Spielman, BA, and Lisa Voltolina, BA.

This publication was supported by the Cooperative Agreement Number 1U59DD000948 from The Centers for Disease Control and Prevention. Its contents are solely the responsibility of the authors and do not necessarily represent the official views of the Centers for Disease Control and Prevention. This publication was produced by the Alaska Department of Health and Social Services. It was printed at a cost of \$2.14 per copy in Anchorage, Alaska. This cost block is required by AS 44.99.210.

This work was also based in part on the Virginia Commonwealth University's *Emergency Preparedness Toolkit for People with Disabilities*.

For additional copies or to order alternative formats of this toolkit, please contact:

State of Alaska Division of Public Health  
Section of Women's, Children's, and Family Health  
3601 C Street, Suite 322  
Anchorage, AK 99501  
Phone: 907-269-3400  
Website: <http://dhss.alaska.gov/dph/wcfh>

For an electronic version of this toolkit, as well as individual checklists and planning tools, go to the Alaska Health and Disability Program Emergency Preparedness page.

# TABLE OF CONTENTS

INTRODUCTION . . . . . 3

    Why an emergency preparedness toolkit? . . . . . 3

    Getting started . . . . . 3

## SECTION 1: What to be prepared for . . . . . 5

    Earthquakes . . . . . 5

    Tsunami . . . . . 7

    Storm or flood . . . . . 8

    Extreme cold . . . . . 9

    House fire . . . . . 10

    Wild fire . . . . . 11

    Avalanche or landslide. . . . . 12

    Power outage . . . . . 13

    Volcanic eruption . . . . . 14

    Terrorist attacks . . . . . 15

    Contagious disease emergencies . . . . . 16

## SECTION 2: Tips for specific disabilities . . . . . 17

    Communication disabilities . . . . . 18

    Intellectual and cognitive disabilities . . . . . 19

    Deaf or hard of hearing . . . . . 20

    Vision disabilities . . . . . 21

    Mobility disabilities . . . . . 22

    Mental health conditions . . . . . 23

    Medical conditions . . . . . 24

**SECTION 3: Making a plan . . . . . .25**

Personal ability plan . . . . . .25  
Building a personal support network . . . . . .32  
My personal support network . . . . . .33  
My neighbor contact list . . . . . .35  
My emergency telephone list . . . . . .37  
My medicine list . . . . . .39

**SECTION 4: Should I stay or should I go? . . . . . .41**

Shelter in place and seal the room . . . . . .41  
Emergency supplies to gather together . . . . . .42  
Storing emergency supplies . . . . . .43  
Storing water . . . . . .43  
Storing food . . . . . .44  
Things to know about your utilities. . . . . .45  
Disability-related supplies and special equipment . . . . . .46  
Emergency papers . . . . . .47  
Evacuation. . . . . .48  
Emergency shelters . . . . . .49  
Emergency "go bag" . . . . . .50  
Prepare your service animals and pets . . . . . .51

**SECTION 5: Resources. . . . . .53**

Summary checklist . . . . . .53  
Family emergency cards. . . . . .57  
Family emergency plan . . . . . .58  
Get out alive! Fire escape planner . . . . . .59  
Alaska resources . . . . . .61

# INTRODUCTION

## Why an emergency preparedness toolkit?

“Emergency preparedness” is a term used to describe a plan to prepare you in case of an emergency. Regardless of your gender, race, or disability, planning for emergencies such as windstorms, earthquakes, or fires is an important part of taking care of yourself. People with disabilities may have special needs to consider in an emergency. If you have a disability, it may require extra planning to handle an emergency.

This toolkit will help you prepare for an emergency. Making an emergency plan and putting together your emergency toolkit is a big job. Your plan may include family, friends, neighbors, and organizations that support you and can help you make decisions. Your toolkit does not have to be perfect, but it is important to plan ahead.

Because everyone’s situation is different, not all subjects of emergency preparedness are covered in this guide. Think about your personal needs and plan for what you will need to stay safe in an emergency.

Remember: Some plan is better than no plan. You can do it!

## Getting started

Know what kinds of emergencies could happen in your area and think about what your neighborhood might look like after one happens. (Page 5)

Complete a personal ability plan. Think about what you will be able to do and what help you may need before, during, and after an emergency. Write down your answers. (Page 25)

Build your own support network of family, friends, neighbors, roommates, care providers, and/or people you work with who could help you in an emergency. (Page 32)

Make an emergency telephone list so others will know whom to call if they find you unconscious, unable to speak, or if they need to help you leave your home quickly. (Page 37)

Make a medicine list with the names and phone numbers of your doctors, your medications, how much you take, and your medical conditions. Write down what special equipment you use, your allergies, and any communication difficulties you have. (Page 39).

Try to keep a seven-day supply of medications with you and fill your prescriptions as early as you can. Ask your doctor or pharmacist what you should do if you can't get more right away. If you get treatments at a clinic or hospital, ask the person who helps you what to do if you can't get your treatments during an emergency. Install at least one smoke alarm on each floor in your home and test them every month. Know evacuation routes and safe places to go during an emergency. (Page 48)

Know where the controls for your water, electricity, gas and sewer are and learn how and when to turn them off during an emergency. (Page 45)

Keep an emergency supply kit in your home, car, workplace, and anywhere you spend your time. Include food, water, a first aid kit, adaptive equipment, batteries, and supplies for your pets or service animals. (Page 42)

Make your home or office safer by checking hallways, stairwells, doorways, windows, and other areas for problems that may keep you from safely leaving a building during an emergency. Secure or move furniture that may block your path.

Fill out a summary checklist to make sure that your emergency plan covers every problem you might have. (Page 53)

## SECTION 1

# What to prepare for

## Earthquakes

*If you are indoors when shaking starts:*

### **DO:**

- Do drop, cover, and hold on.
- Do lie on the floor against an inside wall. Cover your head and neck with your arms.
- Do lock the wheels of your wheelchair, if you use one. Cover your head.
- Do stay away from windows, hanging objects, mirrors, tall furniture, large appliances, and cabinets filled with heavy objects.
- If you are cooking, using gas or electricity, turn them off and move away.
- If you are in bed, do stay where you are. Cover your head with a pillow.
- Do stay inside a building unless there is a fire or gas leak.

### **DO NOT:**

- Do not run out of your house during strong shaking.
- Do not use elevators.
- Do not light matches.

*If you are outside when shaking starts:*

### **DO:**

- Do move to a clear area if you can get there safely.
- If you are driving, do pull to the side of the road and stop in a clear area.
- If you are on a beach or near a harbor, do move to higher ground.

**DO NOT:**

- Do not go near power lines, buildings, or trees.

***When the shaking stops:*****DO:**

- Do ask the people around you if they are hurt. Give them first aid if you know how.
- Do check around you for dangerous conditions, such as fires, fallen power lines, and damage to the building you are in.
- Do put out small fires if you have a fire extinguisher and know how to use it.
- If you don't have a fire extinguisher, buy one and learn how to use it. Keep it somewhere in your house you can reach easily in an emergency, like your kitchen.
- Do hang up phones that have fallen off the hook.
- Do look around your house for damage.

**DO NOT:**

- Do not move people with serious injuries unless they are in danger.
- Do not turn off the gas unless you smell a gas leak. If you do smell gas, turn it off. Call your gas company to have it turned on again. Do not try to turn your gas on again yourself.

***If you are trapped in debris:*****DO:**

- Do cover your nose and mouth.
- Do tap on a pipe or wall so rescuers can hear where you are. Use a whistle or your cell phone if you have it with you.
- Keep your service animal near you, if you have one.

**DO NOT:**

- Do not move around very much. Try not to kick up dust.
- Do not shout. Shout only as a last resort.



# Tsunami (soo-nah-mee)

Tsunami waves can be caused by earthquakes. Even if you do not live close to the ocean or inlet, you may take a vacation or visit close by. You should know what to do no matter where you live.

When you visit an ocean or inlet, ask hotel staff or local residents what their community does if there is a tsunami warning. Ask if there is a particular radio station in the area for emergency information broadcasts. Learn the meaning of siren alarms in that area. In some communities, a certain siren sound may be the warning to evacuate, and a different sound may mean “all clear.” Look for road signs that show the evacuation route, and ask questions about emergency procedures if you do not understand what you have been told.



## ***Move to higher ground quickly if:***

- Authorities give a tsunami warning and tell you to leave your home, campground or hotel.
- You hear a siren alarm and it is not a test.
- The earth shakes so much that you cannot stand, or lasts for longer than 20 seconds.
- You notice water moving away from the shoreline.

# Storm or flood

*If you are experiencing a storm or flood:*

## **DO:**

- Do listen to local radio or television channels for emergency messages and instructions.
- Do unplug electrical appliances. Shut off electric circuits if authorities tell you to leave your home. Shut off the gas service if authorities tell you to.
- If your car stalls during a flood, do get out of the car immediately. Leave it where it is and get to higher ground.

## **DO NOT:**

- Do not walk through water that has come into your basement or garage.
- Do not try to drive over a flooded road.
- Do not walk through moving water. If you must walk through water, make sure it is not moving and use a stick to check how deep it is.
- Do not go near water that is touching power lines that have fallen down.
- Do not allow children to play around high water, storm drains, or any flooded areas.

# Extreme cold

*If the weather is extremely cold:*

## **DO:**

- Do make sure you have dry wood and matches for your woodstove or fireplace, if you use one.
- Do stay in a heated building for as much of the day as possible.
- Do keep warm clothing, gloves, hats, scarves, and a sleeping bag somewhere in your house that you can get to easily.
- Do keep enough food and water for yourself and your service animal (if you have one) to last at least three to five days.
- Do let your water faucets drip if weather conditions are below freezing; this may prevent water pipes from bursting.

## **DO NOT:**

- Do not use candles. They can cause fires.
- Do not use a gas stove or oven to heat your house.
- Do not use generators inside your house or garage.

# House Fire

*If your smoke alarm goes off or you see a fire:*

## **DO:**

- Do stay calm. Get out of your house or the building you are in.
- Do find another way out if you see smoke coming in under the door.
- Do touch the door with the back of your hand before you open it. If it is hot, find another way out.
- Do drop to the floor to avoid smoke fumes. Crawl or roll to a safe place.
- If your clothes catch on fire, do stop where you are, drop to the ground, and roll over and over until the flames are out.
- Do call 9-1-1, if available in your area, from a safe place. Wait for the operator to hang up before you get off the phone.
- If you can't get out of your house or the building you are in, do stay near a window and close to the floor. Signal for help.

## **DO NOT:**

- Do not open doors that feel hot when you touch them with the back of your hand.
- Do not open doors if you see smoke coming in under the door.
- Do not go back into your house or the building you were in until authorities tell you it is safe.



# Wild Fire

*If you live in a rural area that can have wild fires, take these steps to protect your home:*

## **DO:**

- Do thin any black spruce trees on your property.
- Do remove dead grasses from under remaining trees.
- Do keep tall grass away from your house with a 30 foot border of green grass or gravel. It is also best to also remove any trees within this 30 foot border.
- Do make sure you have a fire break around the area you burn your trash and that you stay with the fire while it is lit.
- Do enclose spaces where blowing embers could ignite (like crawl spaces, eaves, and under decks).
- Do place firewood and fuel tanks as far from the house as possible to reduce the risk that these fuels will ignite your home.
- Do have a plan with your neighbors about how to respond to a wild fire.

## **DO NOT:**

- Do not burn trash on windy days.
- Do not go back into your house or the building you were in until authorities tell you it is safe.

Adapted from: Alaska's Interagency Wildland Fire Management partners *Rural Alaska Fire Protection* brochure, 2011.  
Learn more at [www.firewise.org](http://www.firewise.org).

# Avalanche or landslide

*If there is an avalanche or landslide in your neighborhood:*

## **DO:**

- Do listen to local radio or television to stay informed about changes in weather that could cause an avalanche or landslide (such as heavy snow fall or rain).
- Do plant trees or build a retaining wall to protect your property if you know you live in an area where an avalanche or landslide is likely.
- Do stay inside during an avalanche or landslide. Move to a higher level of your home if possible.
- Do take cover under a table or sturdy furniture during an avalanche or landslide.

## **DO NOT:**

- Do not move closer to the slide area after an avalanche or landslide.
- Do not inspect downed power lines or gas lines, wait for help to arrive.
- Do not stay on your property if ordered to evacuate.



# Power outage

*If there is a power outage in your neighborhood:*

## **DO:**

- Do turn off and unplug all your electrical appliances and computer.
- Do leave one light on so you will know when the power outage is over.
- If a traffic signal is not working, do stop at the intersection as if there were a stop sign.
- Do make sure your food is stored at the right temperature. If it is not stored at the right temperature, it may make you sick.
- Do find blankets to keep warm.
- Do text your loved ones to let them know you are okay. Keep messages short so that emergency messages can also get through.

## **DO NOT:**

- Do not use candles. They can cause fires.
- Do not use a gas stove or oven to heat your house.
- Do not use generators inside your house or garage.

# Volcanic eruption

A volcano is a mountain with an opening in it that leads to lava under the ground. When a volcano erupts, lava can come out of the top. A volcanic eruption can cause poisonous gases, flying rocks, and ash. Volcanoes can destroy land and hurt people.

*If there is a volcanic eruption near you:*

## **DO:**

- Do listen to the news on the radio or television for emergency information.
- Do leave your house immediately if authorities tell you to.
- Do watch out for mud flows. They move faster than you can run and can cause you to fall.
- Do wear shirts with long sleeves and long pants.
- Do stay away from ash, especially if you have breathing problems.
- Do use goggles and wear eye glasses instead of contact lenses.
- Do use a dust mask or hold a damp cloth over your face to help you breathe. If possible, keep dust masks in your house, car, and workplace so you can replace them as needed and/or share them with other people.
- Do stay away from windy areas so you don't get ash in your eyes.
- Do stay inside your house unless you think your roof is falling down.
- Do close doors, windows, and all other vents in your house, like chimney vents, furnaces, and fans.
- Do clear heavy ash from flat or low roofs and rain gutters.

## **DO NOT:**

- Do not run car or truck engines. Ash can clog engines and break moving parts, which can cause your car to stall.
- Do not drive when ash is falling unless you have to. If you have to drive, go 35 miles an hour or slower. Carry an extra oil filter and air filter in your car in case you have to drive when there is a lot of ash in the air. Write down how to change the filters and keep that information in your car.





# Terrorist attacks

Terrorists try to cause fear in people by using many types of weapons. They may use chemicals, nuclear weapons, or other explosives to hurt other people. The best way to stay safe from terrorism is to be aware of your surroundings.

## *To stay safe from terrorist attacks:*

### **DO:**

- Do pay attention to your surroundings. Look for things you may need in an emergency, like emergency exits, fire alarms, and fire extinguishers.
- Do tell someone in charge – like a store manager, supervisor, firefighter, or police officer – if you see or hear something that makes you suspicious or feel worried.
- Do stay calm. If there is an emergency, do what authorities ask you to do in order to stay safe.

### **DO NOT:**

- Do not spread rumors. If you are told something about a terrorist attack, check the information with someone you trust.

# Contagious disease emergencies

A contagious disease emergency (such as pandemic flu) makes a lot of people sick. People may not feel well and may have to go to the hospital. If the disease is very serious, it sometimes can cause death.

If there is a contagious disease emergency in Alaska, the State Division of Public Health, local public health nurses, or Community Health Centers will give you information on how to stay healthy. Check for reports in newspapers, on television and the radio.

*If there is a contagious disease emergency:*

## **DO:**

- Do listen to your television or radio for information and instructions from authorities, like the State or local Public Health Center. The news will tell you if a disease is a contagious emergency.
- Do wear protective latex or latex-free gloves and a mask over your nose and mouth if you have to leave the house.
- Do wash your hands often and dry them on clean towels.
- Do cover your mouth and nose with a tissue when sneezing or coughing
- Do avoid touching your eyes, nose or mouth.
- Do avoid contact with those who are not feeling well.
- Do practice other good health habits – get plenty of sleep, be physically active, manage your stress, drink plenty of fluids and eat healthy foods.
- Do seek medical attention from a doctor if you feel flu-like symptoms (high temperature, vomiting, sneezing, coughing, or body chills).

## SECTION 2

# Tips for specific disabilities

An emergency can happen anywhere. While you can expect some help from first responders, it might not come right away. That is why it is important to protect yourself and make sure you can stay safe and healthy if help isn't around.

If you are living with a disability, there are a few extra tips you should keep in mind to get prepared. Start by talking with friends, family or those in your support network about problems you may encounter in an emergency. Talk about whether you will need help and how everyone will stay in contact.

You may have trouble hearing, seeing or understanding official warnings. Talk about those needs and write down a plan. Consider giving your personal support network keys to your home. Show them how to use any assistive equipment. Make sure they are comfortable with your service animal, if you have one.

Think about your daily activities and how an emergency might impact them. For example, think about how you'll stay safe if the power goes out. What if officials tell you to stay indoors for several days? What supplies will you need? What will you need help with? What if your caregiver can't get to you?

Thinking through what you will need in an emergency based on your own abilities and challenges will help you be more prepared.

The American Public Health Association also has emergency preparedness tipsheets for specific disabilities that are available in English, Spanish, accessible PDFs, and American Sign Language. Go to [www.getreadyforflu.org/new\\_pg\\_facts.htm](http://www.getreadyforflu.org/new_pg_facts.htm).





# Intellectual and cognitive disabilities

Part of staying safe during a disaster is following instructions from emergency officials. It also means being prepared and acting quickly. This may be difficult, but there are things you can do to get ready. Remember: An emergency can be a stressful situation filled with distractions, noises and changing directions from officials. Writing down instructions for yourself ahead of time will help you focus and stay calm.

## Practice

Practice what to do during and after an emergency. Be sure to include your service animal in the practice, if you have one.

Practice leaving places you spend your time until you feel confident you will know what to do if there is an emergency.

## Emergency plan

Write (or pictograph) your emergency plan on a piece of paper. Keep it with you and at places you spend a lot of your time. Make sure it is easy to read and understand.

Think about the things you will need to do after an emergency and how you can do them.

Put important items like your ID or house keys in a small bag that you can hang around your neck so you don't lose them.

## Communication

Think about what a police officer or firefighter might need to know about you. Be prepared to say it, or write it down on paper and keep it with you. Here are some examples:

"I talk to people in a different way. I can point to pictures or key words, which you can find in my wallet or emergency supply kit."

"I may have a hard time understanding what you are telling me."

"Please speak slowly and use simple words."

"I forget easily. Please write down information for me."

"I may have a hard time understanding or remembering your instructions. Please speak slowly or write them down for me."



# Deaf or hard of hearing

What would you do in an emergency? How would you communicate with emergency responders? If you're Deaf or hard of hearing, there are some extra things you should keep in mind.

Keep extra batteries in your emergency supply kit for the devices you use to help you communicate.

Keep hearing aids in a place you can find them easily during an emergency.

Put different kinds of alarms in places you spend a lot of time to help you see if an emergency is happening.



## Communication

Think about how you will communicate with police officers and fire fighters. Have paper and pens or pencils with you.

Think about writing down things you need to say on paper and keeping it with you. For example: "I use American Sign Language (ASL) and need an ASL interpreter."

The National Weather Service provides the latest information on dangerous weather and other potential hazards. There are a number of ways you can access the National Weather Service. This may be especially important if you'll have a difficult time hearing community warning systems and sirens. Some National Weather Service radio receivers can be connected to bed shakers, flashing lights or pillow vibrators.

Find out which broadcasting systems use closed captioning or interpreters so you can stay up to date on emergency news. This is especially important if officials call for evacuation or advise you to stay indoors.

Ask neighbors or someone in your support network to help keep you informed. Remember: Your community's emergency warning system may not be equipped to meet your needs. It's up to you to make a plan to keep you and your family safe and healthy.

Check that your local emergency system can interact with TTY or Internet-based relay services. Keep your TTY around even if you rarely use it, in case Internet service goes down.

# Vision disabilities

There are some extra steps you should consider if you're living with a vision disability.

If you have some vision, consider installing security lighting in each room to help you safely move around. Label your preparedness supplies so you can identify them quickly and easily.

Store high-powered flashlights with wide beams and extra batteries where you can find them easily.

Make sure you have extra glasses or contact lenses. You may need to have other things to help you see during an emergency.

If you use a cane, keep extras at work, home, school, and volunteer sites to help you get around obstacles. Keep a spare cane in your emergency kit.

Keep lights in working order so emergency personnel can make their way around in your home in the event of an emergency.

Don't forget about a battery-operated radio. Some TV stations may only broadcast warnings as a text scroll at the bottom of the screen. In that case, having a radio will be critical to learning the latest information.



# Mobility disabilities

When a disaster happens, getting to safety — whether it be to an evacuation shelter or to a safe room in your home — is critical. And if you're living with a mobility disability, there are some extra steps you should take to get ready to stay safe and healthy during an emergency.

Do a personal assessment. Go through all the items you need to live on a daily basis and think about how an emergency will affect them. This is especially important for any assistive devices that depend on electricity or batteries.

Keep your emergency supply kit in a backpack attached to your walker, wheelchair, or scooter.

Keep things that help you get around close to you.



## Emergency kit

Keep sturdy gloves in your emergency kit to protect your hands if you have to travel over snow, ice, glass, dirt, or trash.

Keep extra batteries to make sure your mobility device will work.

If you use a wheelchair, keep a tire patch kit and a can of seal-in-air product handy and make sure you know how to fix a tire.

If you use an electric wheelchair, try and keep a manual wheelchair in your home. It may be easier to bring with you in case of evacuation.

## Escape plan

Identify the easiest route to get around.

Make sure furniture will not get in your way if you need to get out of your house quickly.

If you spend time in a building with an elevator and several floors, plan another way to get out of the building. Practice using the stairs to escape if you can.

If you can't use your wheelchair or the stairs, learn how to tell people how to lift and carry you safely.



# Mental health conditions

If you have a mental health condition, the additional stress of an emergency situation can be hard to manage. Use these tips to make a plan that can help you cope in healthy ways.

Think about what a police officer or firefighter may need to know about you. Be ready to say important information, or write it down and keep it with you. Here are some examples:

"I have a mental health condition and may become confused in an emergency. Please help me find a quiet place. I will be okay shortly."

"I have a panic disorder. If I panic, give me \_\_\_\_\_ *name of your medicine and how much you take* located in my emergency supply kit."

"I take \_\_\_\_\_ *name of your medicine and how much you take* and my blood level needs to be checked."

## Reactions

There are many ways you may react during an emergency. You may:

- Be confused
- Have memory or thinking problems
- Feel anxious or panicky
- Cry or scream
- Feel that everybody is against you
- Have problems sleeping
- Shake or tremble
- Get angry easily
- Not want to be around people
- Feel depressed
- Not be able to sit still comfortably

Think about the reactions you may have. Plan how you will deal with your emotions.

Think about getting advice from your family, friends, or therapist.

You may need medical help or to go to the hospital. Write down the name and phone numbers of the people you would like your doctors to call.

## Medical conditions

If you have complex medical conditions that require a consistent source of electricity or daily support by a personal care attendant, you may need extra help planning for emergencies. Some Alaskan communities maintain registries for individuals who require special assistance. Contact your utility company and let them know if you or a family member depends on medical equipment for life support.

Talk to your medical provider about other steps you can take to assure your safety during an emergency. You should also talk to your local emergency management service. Depending on where you live, this might mean contacting the fire department, the police department, or a local emergency management committee (see the resources section).

### Extra supplies to keep on hand

Make sure to keep at least 7 days of medication you depend on. If you can't keep medication on hand, maintain a list of current prescriptions. You can ask your pharmacist for a current list every time you refill.

If your medication requires refrigeration (such as insulin), consider other methods to keep it cool, like a portable cooler with cold packs. Avoid freezing these medications.

If you depend on electricity for life support, talk to your personal support network about identifying and buying a back up generator for your neighborhood.

## SECTION 3

# Making a plan

This section will help you think about what you can do and what you may need during an emergency. When you make a plan, you gather all the information about your personal support network and your medical needs into one place.

## Personal ability plan

Decide what you will be able to do for yourself and what help you may need before, during, and after an emergency based on your surroundings, your capabilities, and your limitations.

Make a list of your personal needs and your resources for meeting them during an emergency. Think about the questions on the next few pages and write down your answers or record them to share with your support people.

These answers should describe both your abilities right now and the help you may need during an emergency. Plan as if you are having a bad day because of your disability and need a lot of help.

| Communication  |  |
|--|--|
| <i>Do you use a device to help you communicate (like an iPad, communication board, or CapTel)?</i> |  |
| My abilities today:  | Help I may need in an emergency:         |
| <br><br><br><br><br><br><br><br><br><br>   | <br><br><br><br><br><br><br><br><br><br> |

***Do you use American Sign Language (ASL)?***

My abilities today:

Help I may need in an emergency:

***Do you read Braille or written English?***

My abilities today:

Help I may need in an emergency:

**Daily living**

***Do you need help with personal care, such as bathing and grooming?***

My abilities today:

Help I may need in an emergency:

***Do you use adaptive equipment to help you get dressed?***

My abilities today:

Help I may need in an emergency:

***Do you use a shower chair, tub transfer bench, or other similar equipment?***

My abilities today:

Help I may need in an emergency:

***Do you use special utensils that help you prepare or eat food independently?***

My abilities today:

Help I may need in an emergency:

***Do you need special foods or need your foods to be prepared in a special way?***

My abilities today:

Help I may need in an emergency:

## Utilities

*What will you do if your normal source of water is unavailable for several days, or if you are unable to heat water?*

My abilities today:

Help I may need in an emergency:

*How will you use equipment that runs on electricity or batteries— such as dialysis machines, electrical lifts, communication devices, and power chairs — if there is a power outage?*

My abilities today:

Help I may need in an emergency:

## Getting around

*How will you clean up your home after an emergency?*

My abilities today:

Help I may need in an emergency:



***Do you need a specially-equipped vehicle or accessible transportation?***

|  |  |
|--|--|
|  |  |
|--|--|

***How will you get groceries, medications, and medical supplies if your support people are unable to reach you?***

My abilities today:

Help I may need in an emergency:

|  |  |
|--|--|
|  |  |
|--|--|

**Evacuating**

***Building evacuation: Do you need help to leave your home or work place?***

My abilities today:

Help I may need in an emergency:

|  |  |
|--|--|
|  |  |
|--|--|

***Can you get to other exits you can use if the elevator in your building is not working?***

My abilities today:

Help I may need in an emergency:

***How will you call for the help you may need to leave the building?***

My abilities today:

Help I may need in an emergency:

***What will you do if you can't get to your mobility aids?***

My abilities today:

Help I may need in an emergency:



***What will you do if the building ramps have been damaged and can't be used?***

My abilities today:

Help I may need in an emergency:

**Service animals and pets**

***Will you be able to care for your animal during and after an emergency?***

My abilities today:

Help I may need in an emergency:

Updated: \_\_/\_\_/\_\_

Be sure to check and update this form yearly.

# Building a personal support network

Pick at least three people you trust to be your emergency contacts. These people will check on you during an emergency to be sure you're okay and to help you. It is important to choose more than one person in case someone is not available when you need help.

## People you may want to include in your personal support network:

- Family
- Friends
- Personal care attendant/direct support staff
- Neighbors
- Roommates
- Members of your faith community

## Important things to discuss with your personal support network:

Pick and practice a way to communicate. Think about how you would get in touch with each other if your telephone was not working, if your electricity shuts off, or both.

Give a set of your keys to someone you trust.

Show your personal support network where you keep your emergency supplies.

Share copies of your escape plan, emergency papers, and health information card with your personal support network.

Let your personal support network know when you will be out of town. It may be a good idea to leave a telephone number where you can be reached.

Practice your emergency plans with your personal support network to make sure they are able to help you. Ask yourself these questions: Is each person strong enough? Can they all communicate clearly? Can they all guide you safely?

Write reminders on your calendar to ask your personal support network if they are still able to help you.



# My personal support network

|  |             |
|--|-------------|
| Name:  |             |
| Home phone:  | Cell phone: |
| Address:   | Email:      |
| Given copy of personal plan and emergency papers? Yes No If yes, date: _____ |             |
| <b>Personal support 2</b>  |             |
| Name:  |             |
| Home phone:  | Cell phone: |
| Address:   | Email:      |
| Given copy of personal plan and emergency papers? Yes No If yes, date: _____ |             |
| <b>Personal support 3</b>  |             |
| Name:  |             |
| Home phone:  | Cell phone: |
| Address:   | Email:      |
| Given copy of personal plan and emergency papers? Yes No If yes, date: _____ |             |

Updated: \_\_\_/\_\_\_/\_\_\_

Be sure to check and update this form yearly.

Adapted from June Isaacson Kailes, Disability Policy Consultant, Playa del Rey, California and The Center for Disability Issues and the Health Profession, Western University of Health Sciences, Pomona, California  
<http://www.cdihp.org>





# Neighbor contact list

| Neighbor 1     |             |
|----------------|-------------|
| Neighbor name: |             |
| Home phone:    | Cell phone: |
| Address:       | Email:      |
| Neighbor 2     |             |
| Neighbor name: |             |
| Home phone:    | Cell phone: |
| Address:       | Email:      |
| Neighbor 3     |             |
| Neighbor name: |             |
| Home phone:    | Cell phone: |
| Address:       | Email:      |

Updated: \_\_/\_\_/\_\_

Be sure to check and update this form yearly.

Adapted from June Isaacson Kailes, Disability Policy Consultant, Playa del Rey, California and The Center for Disability Issues and the Health Profession, Western University of Health Sciences, Pomona, California  
<http://www.cdihp.org>





# My emergency telephone list

You can cut this page out and keep it on your fridge or in another easy location.

| Emergency: Dial 911 where available |                |
|-------------------------------------|----------------|
| Name                                | Phone number   |
| Police Department (non-emergency)   |                |
| Fire Department                     |                |
| Gas Company                         |                |
| Electric Company                    |                |
| Poison Control                      | 1-800-222-1222 |
| Family                              |                |
| Name                                | Phone number   |
|                                     |                |
|                                     |                |
|                                     |                |
| Friends/Co-workers                  |                |
| Name                                | Phone number   |
|                                     |                |
|                                     |                |
|                                     |                |
|                                     |                |
|                                     |                |

Updated: \_\_/\_\_/\_\_

Be sure to check and update this form yearly.





# My medicine list

This medication form can be used keep track of your medicines and important provider information. Cut it out and keep it with your emergency papers.

This list was updated:

## My Medicine List

Name: \_\_\_\_\_  
 Phone: \_\_\_\_\_  
 Email: \_\_\_\_\_  
 My emergency contact is \_\_\_\_\_  
 Phone: \_\_\_\_\_ Email: \_\_\_\_\_  
 My doctor's name is \_\_\_\_\_  
 Phone: \_\_\_\_\_  
 My pharmacy's name is \_\_\_\_\_  
 Phone: \_\_\_\_\_  
 I am allergic to \_\_\_\_\_  
 \_\_\_\_\_  
 I also have some other problems with medicines: \_\_\_\_\_  
 \_\_\_\_\_  
 \_\_\_\_\_

### Keeping My Medicine List Up-to-Date

It is very important to keep this information current. Use the chart on the back of this page to review and update your list of medications. You can do this with your doctor, pharmacist, nurse or other health care professional.

Questions for my doctor or pharmacist: \_\_\_\_\_  
 \_\_\_\_\_  
 \_\_\_\_\_

**Use the chart to fill out your medicine list!**

### How to Use Your Medicine List

Your medicine list can help you and your family keep track of everything you take to keep you healthy—your pills, vitamins and herbs. Having all of your medicines listed in one place will also help your doctor, pharmacist, hospital or other health care workers take care of you!

- First, fill out the form. Make sure ALL of your medicines are in front of you. Include prescribed medication AND any over-the-counter medicines, vitamins, herbs and minerals. Ask for assistance from a healthcare professional if you need help.
- Next, think about what you take in the morning, afternoon, around dinner time and before you go to bed.
- Then, for every medicine, use the chart to record the following information:
  - The medicine's name and the dose
  - How much you take of it (1 pill, 3 drops, etc.)
  - What it looks like (round, white and red, clear liquid, etc.)
  - How it's taken (by mouth, with food, by injection)

Here's an example:

| Medicine name<br><small>(brand name, generic name, dose)</small> | How much?           | This looks like    | How I take it            |
|--|---------------------|--------------------|--------------------------|
| <i>Example - Aspirin 81 mg</i>                                   | <i>1 pill daily</i> | <i>pink tablet</i> | <i>orally with water</i> |

- Always keep this list with you—put it in your wallet or your purse, so you will have it every time you see the doctor, your pharmacist, have a test, go to the hospital or have an emergency.
- When you stop or start a medication, make sure to update your list.
- If you have any questions about the medicines you are taking, be sure to contact your doctor or pharmacist.

**Quality Improvement Organizations**  
Sharing Knowledge. Inspiring Health Care.  
 CENTERS FOR MEDICARE & MEDICAID SERVICES

This material was produced by Mountain-Pacific Quality Health, the Medicare Quality Improvement Organization for MT, WY, HI and AK, under contract with the Centers for Medicare & Medicaid Services (CMS), an agency of the U.S. Department of Health and Human Services. Contents do not necessarily reflect CMS policy. 10H50W-MPQH-46-13-48



## SECTION 4

# Should I stay or should I go?

The first important decision you need to make during an emergency is whether you should stay where you are or leave. Plan for both possibilities and use your common sense and good judgment to make decisions with the information you are given.

Local authorities may not always be able to give information about what is happening or what you should do immediately. You should watch the news on television or listen to a local radio news report for information and instructions as they become available.

If local authorities tell you to leave your home or seek medical treatment, grab your "go bag" and your emergency papers and leave immediately.

## Shelter in place and seal the room

There may be times when it is safer to stay where you are than leave. If you see debris in the air, or if local authorities say the air is contaminated, stay inside! If the air is contaminated, it can be dangerous to breathe.

*Here are some steps you can take to stay safe at home:*

- Bring your family and pets inside.
- Lock your doors and close windows, pet doors, air vents, woodstove and fireplace dampers.
- Seal all the windows, doors, air vents, pet doors, woodstove and fireplace openings with plastic sheeting and duct tape. Think about measuring and cutting plastic sheeting ahead of time to save time during an emergency.
- Turn off fans and forced air heating systems.
- Stay in a room at the center of your house that doesn't have many or any windows. Take your emergency supply kit, blankets, and something to do while you are waiting for the air to clear.
- Watch the news on television, listen to local radio news reports, or check the Internet often for official news and instructions from local authorities.
- You can text loved ones to let them know you are okay.

## Emergency supplies to gather together

- The purse or bag you usually use
- Extra money. Keep the amounts small, like five or one dollar bills and quarters, dimes and nickels. (ATMs may not work during a power outage.)
- Bottled water and water purification tablets
- Food: store enough canned or dried food to last 5 to 7 days
- First Aid supplies and fire extinguisher
- Can opener
- Paper towels
- Plastic bags for throwing away trash
- Toilet paper and feminine products
- Hand sanitizer or liquid soap
- Bleach for making water drinkable (see next page for instructions)
- Paper to write on and pens, pencils or crayons
- Cell phone. Save your emergency contacts' phone numbers under the name ICE, this stands for In Case of Emergency. Police officers or firefighters may access the number if you need help.
- Health Information Card
- Emergency papers, like vaccination records and insurance policy numbers
- Medicine and copies of your prescriptions. Make sure you have enough medicine to last at least 7 days.
- Flashlight that runs on batteries or can be wound
- Signaling device, like a whistle or bell
- Small radio that runs on batteries or can be wound
- Watch or clock that runs on batteries or can be wound
- Blankets and sleeping bags
- Extra batteries
- Walking stick
- Cook stove with fuel and matches
- Heavy gloves
- Duct tape
- Plastic sheeting
- Cloth tape to wrap your feet under your socks to prevent blisters
- A full change of clothing
- Extra socks
- Comfortable shoes
- Special equipment specific to your needs, like extra contact lenses or glasses, communication devices, laptop computers, hearing aids and batteries, or mobility aids
- Hat, sunglasses, personal water bottle
- What other items do you think you'll need?
- Other \_\_\_\_\_



## Storing emergency supplies

Make sure the supplies you put in your emergency supply kits work and won't break easily.

Choose a safe place for your emergency supply kits. Spaces that are cool in temperature and dark, like a closet or an accessible place in your garage, are good options.

If you live in an apartment or don't have a lot of space, get creative! Put your emergency supply kits under your bed or stairs.

Layer supplies in your emergency supply kit in a large container, like a plastic garbage can on wheels.

Put toothbrushes, soap, eating and cooking utensils, and personal supplies into a box and place it at the bottom of the container.

Next, put in blankets and clothing.

Put water, food, and your first aid kit on top so you can reach them easily.

If you're a camper or backpacker, you already have a head start. You can use the tent, stove, and other gear you use for fun as part of your emergency supplies.

## Storing water

Store enough water so that everyone in your family will have enough to drink for at least 3 days. Here are some things to consider when storing water:

Each person in your family will need about one gallon of water every day to drink, wash, and cook with. Keep drinking water sealed until you use it and do not let anyone put their hands in it.



Your pets or service animals need water too! Store extra water for your pet to drink.

Put reminders on your calendar to replace the water in your emergency supply kits every six months. Even water tastes funny if you don't drink it soon enough!

In the winter, water may freeze. Try to keep water above freezing if possible.

In some emergencies, you may need to take water from your hot water heater. Remember to turn off the gas or electricity to the tank before you take any water. Water from your hot water heater is not safe to drink or use for cooking or cleaning unless you bring it to a rolling boil and let it cool. To make water clean enough that it's safe to drink, you can boil the water, use water purification tablets or filter systems, or add a few drops of household bleach to it.

Adding bleach to your water can be tricky. Look at the ingredients on the bottle of bleach. Make sure it contains 5.25% hypochlorite in it and no detergent or other added ingredients which are harmful to drink. The Federal Emergency Management Agency (FEMA) suggests adding 16 drops of bleach to a gallon of contaminated water to make it safe to drink.

## Storing food

Canned foods can be stored easily and last a long time. Choose items like ready-to-eat canned meats, fruits, and vegetables that you and your family enjoy.

Buy canned or dried juice mixes, powdered or canned milk, cereals and rice.

Choose foods that are “high energy,” like peanut butter, jelly, crackers, unsalted nuts, and trail mix.

Make sure your food is stored at the right temperature. Some foods spoil if they are not stored the right way, and you may get sick if you eat them.

Remember to rotate your food. Most food comes with an expiration date on it. Eating food after that date can make you sick, so put a reminder on your calendar to check your foods every 6 months so you’re sure they are safe to eat. Eat the food that is going to expire soon and buy new food for your emergency supply kit.

Don’t forget your pets and service animals! Store canned or dried pet food and an extra collar and leash. Pets are usually not

allowed in emergency shelters, so you may have to leave them at home with extra food and water if local authorities tell you to evacuate.

Remember to pack a can opener, cooking and eating utensils, and some basic food seasonings in your emergency supply kit.

## What foods to include

Pick foods that you and your family enjoy.

It is very important that you choose foods that you and your family like to eat. Think about choosing foods you and your family enjoy but don’t get to eat very often.

Choose foods that are easy to make or ready to eat.

When you use the food in your emergency kit, you may have been evacuated from your home, so you won’t have your usual cooking supplies. You may have to stay in a Red Cross Shelter, campground, or in your car while you drive to a safe place. Pick foods that are easy to make or do not need to be cooked.

Don’t spend a lot of money.

Foods that don’t need to be cooked can be expensive. Make a budget for the food you buy for your emergency supply kits and only buy what foods you will be able to use in an emergency.

## Examples of foods to pack

Here's a list of foods that you may want to add to your emergency supply kit:

- Dried beef or salmon jerky
- Canned meat
- Canned or powdered milk
- Raisins
- Peanuts
- Granola bars or power bars
- Trail mix
- Saltine crackers or pilot bread
- Canned soup
- Canned vegetables, or fruit such as applesauce
- Juice



## Things to know about your utilities

If there is damage to your home or local authorities tell you to turn off your utilities, there are important things to keep in mind:

- Know where the electric, gas, and water shut off valves are located.
- Keep the tools you'll need near the shut off valves for easy access.
- If you have a hot water heater, make sure it is strapped to the wall (in case of earthquake.)
- It's a good idea to teach your family members how to turn off the utilities.
- If you turn the gas off, a professional must turn it back on. Don't try to do it yourself!

Even if you live in an apartment, it is possible that the manager or landlord does not live on the property or is not able to turn off utilities. You may need to do it or you may need to be able to tell someone else how to do it. It is a good idea to hold an emergency planning meeting with your manager and all the residents in your building or complex.

Adapted from: [www.ready.gov](http://www.ready.gov)



# Disability-related supplies and special equipment

Put a check in the box next to the items you use. Write down where you keep them and any information about them you may need during an emergency. Label your supplies with your name.

- Supplies for your service animal \_\_\_\_\_
- Eye glasses/contact lenses \_\_\_\_\_
- Eating/grooming utensils \_\_\_\_\_
- Dressing devices \_\_\_\_\_
- Writing and/or communication and/or hearing aids \_\_\_\_\_
- Oxygen/flow rate equipment/monitors \_\_\_\_\_
- Suction and/or dialysis equipment \_\_\_\_\_
- Sanitary supplies \_\_\_\_\_
- Urinary supplies \_\_\_\_\_
- Ostomy supplies \_\_\_\_\_
- Wheelchair (motorized or manual) and repair kit \_\_\_\_\_
- Walker/cane/crutches \_\_\_\_\_
- Dentures or retainers \_\_\_\_\_
- Anything else? \_\_\_\_\_





## Emergency papers

Think about the important papers you may need if you have to move to a new city or state. Add copies of these to your emergency supply kit (page 42). Think about how you will store these papers. A waterproof binder or folder that can fit in a bag is a good way to keep them safe and dry. You could also put the copies in a sealed envelope that is not to be opened unless there is an emergency. Another way to easily store copies of important documents is to use a scanner to put electronic copies onto a password-protected computer, flash drive, or CD.

Some people like to have their family photographs converted to a computer format so that those special memories can be saved in an emergency, too.



### Emergency papers can include copies of:

- Photo ID/driver's license/passport
- Contact information for relatives, caregivers and/or friends
- License and shot record for your service animal, if necessary
- Map of your area (showing where your house is)
- List of your medical equipment/supply needs
- Style/serial numbers of medical devices (e.g., wheelchair)
- Completed "My medicine list" (see page 39)
- Legal papers such as wills, deeds, marriage certificates and divorce papers, power of attorney
- School papers, like diplomas
- Birth certificate
- Military discharge papers
- Credit card account numbers and contact information for company
- Family photographs
- Copies of prescriptions

Adapted from: [http://www.partnership.vcu.edu/documents/PPD\\_Emergency\\_Preparedness\\_Tool\\_Kit\\_for\\_People\\_with\\_Disabilities.pdf](http://www.partnership.vcu.edu/documents/PPD_Emergency_Preparedness_Tool_Kit_for_People_with_Disabilities.pdf)

# Evacuation

If you smell gas, see smoke or fire, or fear for your safety for other reasons, immediately evacuate everyone in your home. Once you are in a safe location, call 9-1-1 and report what happened.

If local authorities tell you to evacuate, follow their instructions. Use the evacuation routes they give you, and carpool if possible. Follow these steps if you are told to leave your home:

**Decide where you will go beforehand, if you can.** Think about at least three places you could go, like a friend or family member's house, a hotel, or a motel outside the area you live. Sometimes public emergency shelters do not provide all the help you may need. Call for transportation if you need help. Plan more than one way to leave your home and be ready to leave early. Think about how you will call for transportation help if the phones and electricity are not working. In some areas, local government agencies provide transportation for people who need help during an emergency. Ask your local Emergency Management Office or fire department if transportation services are available for people with disabilities where you live.

**Grab your "go bag".** Make sure you take your "go bag" and that it contains your medicine and important documents. Put items that are important to you in the "go bag," or someplace safe.

**Know what equipment you need.** Decide what type of equipment you need to help you. If you can't use the stairs, talk to your emergency support people about how you can leave your building in an emergency.

**Take care of your pets.** Unlike service animals, pets may not be allowed into emergency shelters. Contact your local Red Cross chapter, Humane Society or your veterinarian for more information about where you can take your pet while you are at a shelter.

**Turn off the electricity.** Except for the refrigerator or freezer, all your electricity should be turned off at the main box.

**Call your personal support network.** It's important that you call the people in your personal support network to let them know you are safe and where you are going. If you plan to leave the area or the state, you may know a telephone number where you will be able to be reached. Give them that number.

**Advocate for yourself.** Practice how to quickly explain how to guide or move you and your adaptive equipment safely and rapidly. Be ready to give brief, clear, and specific instructions to rescue personnel, either verbally or in writing.

**Practice your plan.** Practice, practice, practice! Identify any obstacles you may experience. Get your personal support network involved. Ask them to practice how to help you. Practice on different days of the week, and at different times of the day. Evacuating when it is daylight is not the same as evacuating at night when you

may not be able to see landmarks that usually guide you. Practice using more than one evacuation route, since some routes may be blocked by the disaster.

**Review and revise your plan.** Review and revise your plan often or as your condition changes or your area is changed (such as when new streets are opened or old streets closed). Make sure that if you change your support network people, they practice with you and know your plan.

## Emergency shelters

When an emergency happens, local authorities will choose emergency shelters for people to go to in order to stay safe. They can't tell you where to go before an emergency happens because they need to make sure the shelters are safe and have not been damaged.

You can find out what shelter to go to by listening to your local radio news broadcast, watching the television news, or by calling or texting your local Red Cross office. If it is not safe to stay where you are and you don't have another safe place to go, get to a chosen emergency shelter and stay there until the emergency is over. Remember to:

- Take your emergency "go bag" with you to the shelter.
- Tell your personal support network where you are going (page 33).

At first, emergency shelters may not be able to give you basic supplies. Consider bringing extra items you may need, like a blanket, pillow, air mattress, towel, washcloth, food, and supplies for children and babies.

Only service animals are allowed in emergency shelters. If you can't make other plans for your pets, Animal Care and Control staff at the emergency shelter may be able to help you find a safe place for your pet.



# Emergency "go bag"

It is a good idea to keep a "Go Bag," a backpack or bag you can carry with you to hold your keys, cell phone, wallet, credit cards, a change of clothes, medications, medical supplies, food, water, money, checkbook, identification cards, flashlight, and pet supplies. Remember to bring this bag with you if you have to leave your home quickly because of an emergency.

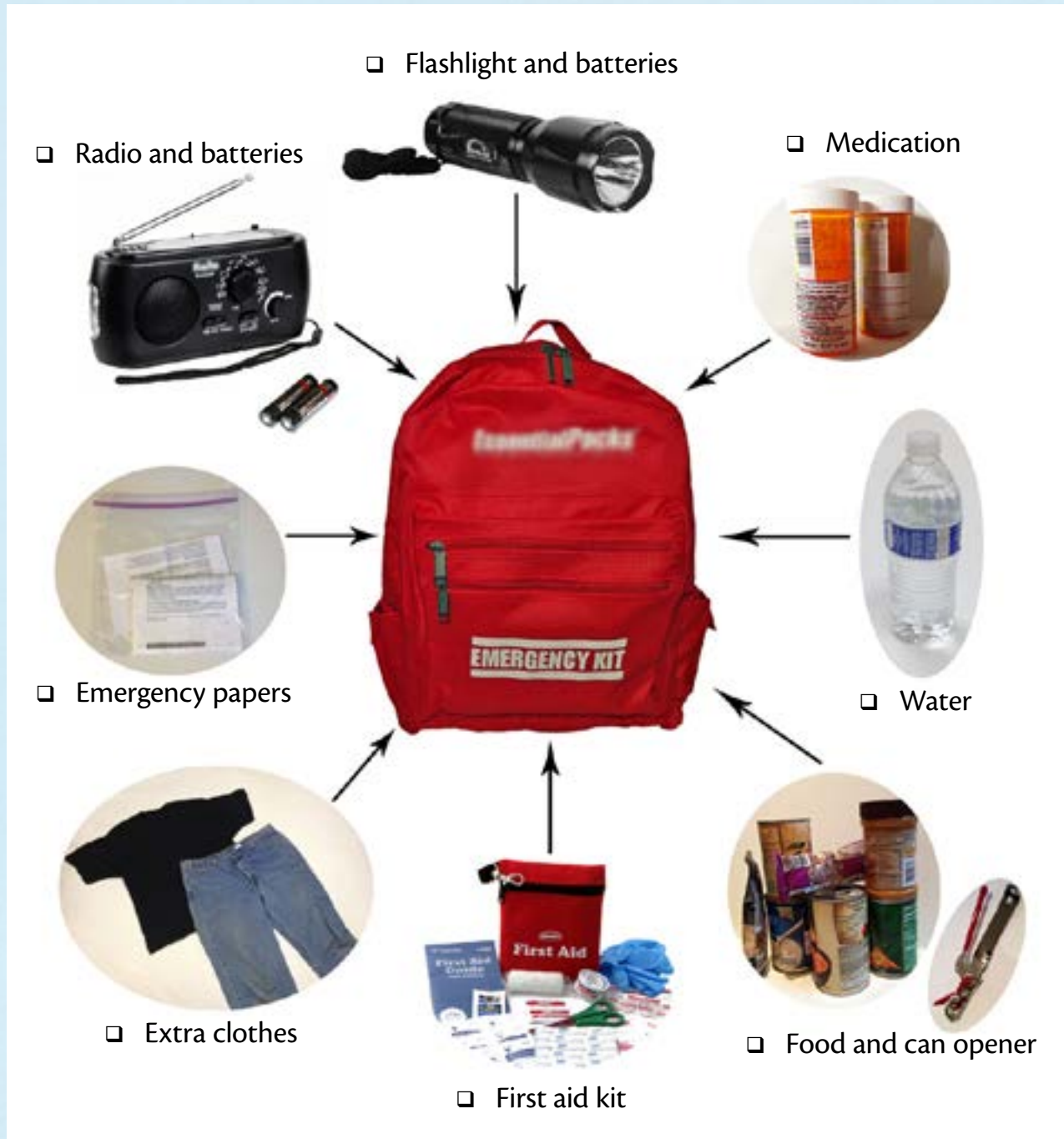

Photo Credit: Camera, back pack, and radio courtesy of Essential Packs at <http://www.essentialpacks.com/>

# Prepare your service animals and pets

The Americans with Disabilities Act (ADA) describes a service animal as a dog that is individually trained to do work or perform tasks for people with disabilities. Service animals are different than pets. They can go into public places where pets are usually not allowed.

In an emergency, a service animal must be allowed to come inside a shelter, clinic, or any other facility related to the emergency with their owners. A service animal can be made to leave only if it threatens the health or safety of other people, or bothers people with bad behavior, like barking.

## Things to consider

Buy stickers or make a sign to put on your doors and windows to show the types of animals you have and where they may be in your house.

Make sure your service animals and pets have current licenses and ID tags. Your telephone number and your out-of-town contact person's phone number should be on them.

Become friends with other animal owners in your neighborhood so someone can help your animals if you are not home.

Plan who will care for your pet if you have to leave your home in an emergency and can't bring it with you.

Be prepared to get along without help

from your service animal. Practice your emergency plans using other mobility helpers. If you have a pet in a carrier, you have a greater chance of having emergency shelter personnel allow the pet into the shelter.



## An emergency supply kit for your service animal or pet

In an emergency, your service animal or pet will need supplies too! Here are some supplies to think about:

- ❑ A bowl for water
- ❑ A seven-day supply of food
- ❑ A two-week supply of water in plastic gallon jugs
- ❑ A blanket or newspaper to sleep on
- ❑ Plastic bags and paper towels for disposing of waste
- ❑ Rubber gloves for you to use when disposing of waste
- ❑ A favorite toy
- ❑ An extra collar and leash, a muzzle (if needed)

- ❑ Medicine(s) your animal needs
- ❑ A carrier that has your contact information on it. Make sure you have one for each animal.
- ❑ Consider including boots for your animal so it can walk through debris.

## Pet identification

Take a photo of your service animal or pet beside an object that will show its size (like a dining room chair or a kitchen stove). Take a picture of the face and then a picture showing the animal from the side. On the back of the picture, write:

- ❑ The animal's name and owner contact information
- ❑ The current date
- ❑ If the animal has an identification chip implanted, note that
- ❑ Your veterinarian's name, address and contact info
- ❑ What shots your animal has had & when
- ❑ What medications the animal takes, if any, & the dosages
- ❑ What food the animal normally eats
- ❑ Any allergies the animal might have

Source: National Organization on Disability. *Disaster Readiness Tips for Owners of Pets and Service Animals* 2007.





## SECTION 5

# Other tools and resources

The following section includes some additional resources you might find useful.

## Summary checklist

Write the date you finish each part of your emergency preparedness plan in the space provided. Update your checklist regularly.

### 1. Make an emergency telephone list (page 37). Include:

- Emergency contact information
- Emergency out-of-town contacts
- Name and number of a relative or friend who lives more than 100 miles away

Date completed: \_\_\_\_\_

### 2. Write down the best way to communicate with you on a card or piece of paper that you can always carry with you if you have communication difficulties.

Date completed: \_\_\_\_\_

### 3. Fill out a medicine list (page 39). Include:

- Medical providers
- Medications you use
- Adaptive equipment and system support equipment you use
- Allergies and sensitivities
- Communication or cognitive difficulties

Date completed: \_\_\_\_\_

**4. Attach copies of health insurance cards and related information to your medical information list.**

Date completed: \_\_\_\_\_

**5. Keep enough of your medications to last 7 days at all times. Fill your prescriptions at the earliest date possible. Remember: Prescriptions for non-narcotic medicines can be used only one year after they are written, and narcotic prescriptions can be used for only 6 months. Put reminders on your calendar to check your medications and prescriptions monthly.**

Date completed: \_\_\_\_\_

**6. Have extra copies of your prescriptions.**

Date completed: \_\_\_\_\_

**7. Talk with your doctor or pharmacist about what you should do if you do not have enough medicine during an emergency. Find out how long your medication is usable and what temperature to keep it at.**

Date completed: \_\_\_\_\_

**8. Determine how often you should replace medication. Put reminders on your calendar.**

Date completed: \_\_\_\_\_

**9. Identify safe places to go during a/an:**

- Earthquake
- Flood
- Fire
- Tsunami
- Terrorist attack

Date completed: \_\_\_\_\_



**10. Install at least one smoke detector and one carbon monoxide detector on each level of your home and near the rooms you sleep in.**

Date completed: \_\_\_\_\_

**11. Find utility cutoff valves and switches. Learn how to use them.**

Date completed: \_\_\_\_\_

**12. Identify as many exits as possible from each room in your home and the buildings you spend your time in.**

Date completed: \_\_\_\_\_

**13. Make a floor plan of your home that includes your main escape routes to keep posted on the refrigerator or other easy place to see (page 59).**

Date completed: \_\_\_\_\_

**14. Practice leaving your building from different exits, especially if you are in a building with many stories.**

Date completed: \_\_\_\_\_

**15. Decide what type of equipment you will need for help during an evacuation.**

Date completed: \_\_\_\_\_

**16. Be ready to give brief, clear, specific instructions and directions to rescue personnel.**

Date completed: \_\_\_\_\_

**17. If you do not drive, talk with your support people about how you will leave the area if authorities tell you to leave.**

Date completed: \_\_\_\_\_

**18. Ask your local Emergency Management Office if transportation services are available for people with your disability during an emergency evacuation. Find out how to get the service.**

Date completed: \_\_\_\_\_

**19. Learn all about the emergency evacuation plan for your office, school, and any other location where you spend a lot of time.**

Date completed: \_\_\_\_\_

**20. Choose a place to stay if you can't go home.**

Date completed: \_\_\_\_\_

**21. Have a care plan for your pet and/or service animal.**

Date completed: \_\_\_\_\_

Sample Family Emergency Plan cards can be viewed and completed by visiting [www.ready.gov](http://www.ready.gov). Print out a copy and use scissors to cut the cards. Keep cards in your wallet, purse, or backpack.



Prepare. Plan. Stay Informed.



# Family Emergency Plan



Make sure your family has a plan in case of an emergency. Fill out these cards and give one to each member of your family to make sure they know who to call and where to meet in case of an emergency.

Additional Important Phone Numbers & Information

**Family Emergency Plan**

EMERGENCY CONTACT NAME:  
TELEPHONE:

OUT-OF-TOWN CONTACT NAME:  
TELEPHONE:

NEIGHBORHOOD MEETING PLACE:  
TELEPHONE:

OTHER IMPORTANT INFORMATION:

DIAL 911 FOR EMERGENCIES

Ready

< FOLD HERE >

Additional Important Phone Numbers & Information

**Family Emergency Plan**

EMERGENCY CONTACT NAME:  
TELEPHONE:

OUT-OF-TOWN CONTACT NAME:  
TELEPHONE:

NEIGHBORHOOD MEETING PLACE:  
TELEPHONE:

OTHER IMPORTANT INFORMATION:

DIAL 911 FOR EMERGENCIES

Ready

Additional Important Phone Numbers & Information

**Family Emergency Plan**

EMERGENCY CONTACT NAME:  
TELEPHONE:

OUT-OF-TOWN CONTACT NAME:  
TELEPHONE:

NEIGHBORHOOD MEETING PLACE:  
TELEPHONE:

OTHER IMPORTANT INFORMATION:

DIAL 911 FOR EMERGENCIES

Ready

< FOLD HERE >

Additional Important Phone Numbers & Information

**Family Emergency Plan**

EMERGENCY CONTACT NAME:  
TELEPHONE:

OUT-OF-TOWN CONTACT NAME:  
TELEPHONE:

NEIGHBORHOOD MEETING PLACE:  
TELEPHONE:

OTHER IMPORTANT INFORMATION:

DIAL 911 FOR EMERGENCIES

Ready

Share this plan with family members. You can cut this page out and keep it on your fridge or in another easy location.



Prepare. Plan. Stay Informed.

# Family Emergency Plan



Make sure your family has a plan in case of an emergency. Before an emergency happens, sit down together and decide how you will get in contact with each other, where you will go and what you will do in an emergency. Keep a copy of this plan in your emergency supply kit or another safe place where you can access it in the event of a disaster.

Neighborhood Meeting Place: \_\_\_\_\_

Phone: \_\_\_\_\_

Out-of-Neighborhood Meeting Place: \_\_\_\_\_

Phone: \_\_\_\_\_

Out-of-Town Meeting Place: \_\_\_\_\_

Phone: \_\_\_\_\_

Fill out the following information for each family member and keep it up to date.

Name: \_\_\_\_\_

Social Security Number: \_\_\_\_\_

Date of Birth: \_\_\_\_\_

Important Medical Information: \_\_\_\_\_

Name: \_\_\_\_\_

Social Security Number: \_\_\_\_\_

Date of Birth: \_\_\_\_\_

Important Medical Information: \_\_\_\_\_

Name: \_\_\_\_\_

Social Security Number: \_\_\_\_\_

Date of Birth: \_\_\_\_\_

Important Medical Information: \_\_\_\_\_

Name: \_\_\_\_\_

Social Security Number: \_\_\_\_\_

Date of Birth: \_\_\_\_\_

Important Medical Information: \_\_\_\_\_

Name: \_\_\_\_\_

Social Security Number: \_\_\_\_\_

Date of Birth: \_\_\_\_\_

Important Medical Information: \_\_\_\_\_

Name: \_\_\_\_\_

Social Security Number: \_\_\_\_\_

Date of Birth: \_\_\_\_\_

Important Medical Information: \_\_\_\_\_

Write down where your family spends the most time: work, school and other places you frequent. Schools, daycare providers, workplaces and apartment buildings should all have site-specific emergency plans that you and your family need to know about.

**Work Location One**

Address: \_\_\_\_\_

Phone: \_\_\_\_\_

Evacuation Location: \_\_\_\_\_

**School Location One**

Address: \_\_\_\_\_

Phone: \_\_\_\_\_

Evacuation Location: \_\_\_\_\_

**Work Location Two**

Address: \_\_\_\_\_

Phone: \_\_\_\_\_

Evacuation Location: \_\_\_\_\_

**School Location Two**

Address: \_\_\_\_\_

Phone: \_\_\_\_\_

Evacuation Location: \_\_\_\_\_

**Work Location Three**

Address: \_\_\_\_\_

Phone: \_\_\_\_\_

Evacuation Location: \_\_\_\_\_

**School Location Three**

Address: \_\_\_\_\_

Phone: \_\_\_\_\_

Evacuation Location: \_\_\_\_\_

**Other place you frequent**

Address: \_\_\_\_\_

Phone: \_\_\_\_\_

Evacuation Location: \_\_\_\_\_

**Other place you frequent**

Address: \_\_\_\_\_

Phone: \_\_\_\_\_

Evacuation Location: \_\_\_\_\_

| Name | Telephone Number | Policy Number |
|------|------------------|---------------|
|      |                  |               |
|      |                  |               |
|      |                  |               |
|      |                  |               |
|      |                  |               |

Dial 911 for Emergencies

# Get Out Alive! A Fire Escape Planner

This is your fire escape planner. If a fire starts, smoke and heat can kill you unless you plan in advance to escape quickly. You may have only several minutes to reach safety. Everyone needs to know how to get out so they can act quickly and without panic.

## Your fire safety plan requires:

- Smoke detector on each level of your home.
- Fire extinguisher on each level of your home.
- Escape routes marked on a floor plan
- Specified meeting place outside your home.
- Plan to evacuate everyone in 150 seconds, including children who can't get out by themselves.
- Practice your escape plan monthly. Practice at different times of the day and using alternate exits.

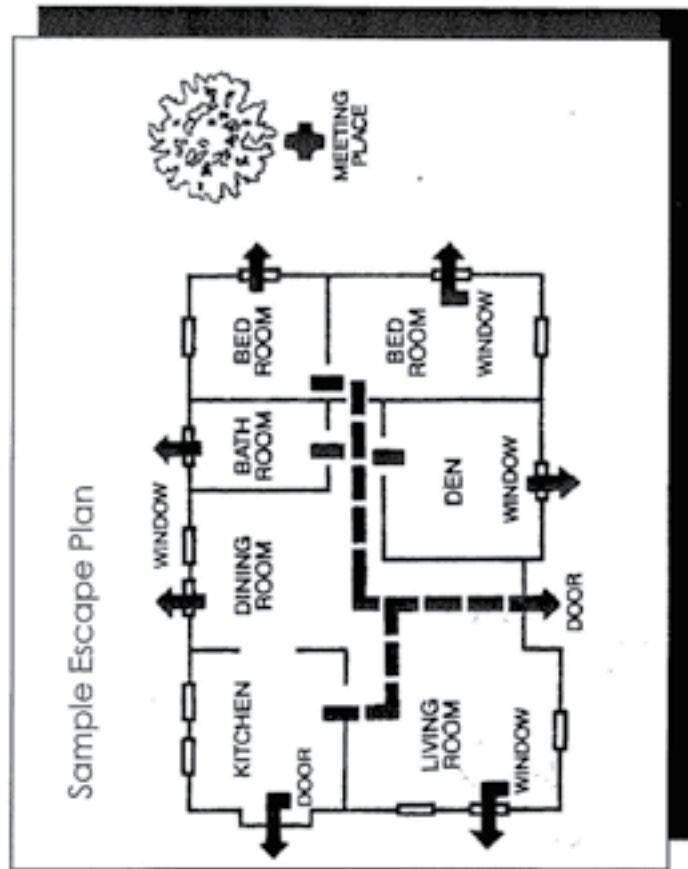



Facility Name:

Date:

**Floor Plan:**

1. Use the grid to draw a floor plan of your whole house. (Drawing does not need to be to scale.)
2. Show two exits from every room.
3. Write down the outside meeting place.

**Exit Procedures:**

1. Sleep with bedroom doors closed. They will hold back deadly smoke.
2. Teach everyone to recognize the sound of your smoke alarms.
3. Test doors before opening them. If hot, use your alternate escape. If cool, brace your shoulder against the door and open it cautiously. Be ready to slam it if smoke or heat rush in.

4. Crawl low under smoke.
5. If your clothes catch on fire: stop, drop and roll.
6. Get out fast.
7. Choose a specific meeting place so you can see that everyone is out of the house.
8. Don't go back inside once you're out.
9. Call the fire department from a neighbor's house.

D084-LIC-03 (Rev. 2/94)

# Resources

Visit these websites if you would like to learn more about emergency preparedness:

Alaska 2-1-1 has information on critical health and human services around Alaska, including emergency-related services

American Red Cross (general information)

ATLA (Assistive Technology of Alaska) has free communication cards and other emergency preparedness resources

Centers for Disease Control and Prevention, Emergency Preparedness and Response (general information)

Department of Homeland Security's Ready Campaign for individuals with functional and access needs

National Organization on Disability's Emergency Preparedness Materials

State of Alaska's Department of Homeland Security and Emergency Management, the State's website for emergency planning

List of local emergency planning committees

Homeland Security & Emergency Preparedness 7 Day Survival Kit

State of Alaska's Division of Public Health, Section of Women's, Children's, and Family Health, Disaster Preparedness for Families with Children and Youth with Special Health Care Needs

Substance Abuse and Mental Health Services Administration, has additional information on disaster-related mental health needs



Information from this toolkit was adapted from invaluable resources and publications developed by national and regional organizations, including:

*American Red Cross*

*The Department of Homeland Security*

*The Federal Emergency Management Agency (FEMA)*

*The Independent Living Resource Center of San Francisco*

*June Isaacson Kailes and the Center for Disability Issues and the Health Professions (Western University of Health Sciences, Pomona, CA)*

*The National Organization on Disability*

*The Emergency Preparedness Toolkit for People with Disabilities (2007) developed by the Occupation Therapy Department at Virginia Commonwealth University and the Virginia Leadership Education in Neurodevelopmental Disabilities (Va-LEND)*

*Tony Cahill, PhD and the University of New Mexico Center for Development and Disability*

This document is available online:

Alaska Health and Disability Program

For more information about this document or to request copies, contact

907-269-3400.